

SCANNED
+ final

THE CITY OF NAPOLEON

BUILDING & ZONING DEPARTMENT

255 W. RIVERVIEW

(419)592-4010

Sign Permit

Permit Number: SG2007-15

Page 1 of 1

Printed: 8/16/2007

ADDRESS:

800 Glenwood Ave.

Applicant

Name: Risun Enterprises, LLC
Address: 208 E Lugbill Rd

Approval Date: 8/16/2007
419-446-2972

Owners

Name: First Church of God
Address: 800 Glenwood Ave
Napoleon, OH 43545

Phone: 419-599-1156

Contractors

Contractor Type: **Sign**

Name: Risun Enterprises, LLC
Address: 208 E Lugbill Rd

Archbold, OH 43502

Phone: 419-446-2972

Fees and Receipts:

Number	Description	Amount
FEE2007-449	Sign (Auto)	\$35.00

Total Fees: \$35.00

RCPT2007-361		\$35.00
--------------	--	---------

Total Receipts: \$35.00

Condition: Lighted sign will be off w/timer @ 10pm

APPLICANTS SIGNATURE: _____

DATE: _____

REMINDER: YOU MUST CALL (419)592-4010 FOR AN INSPECTION

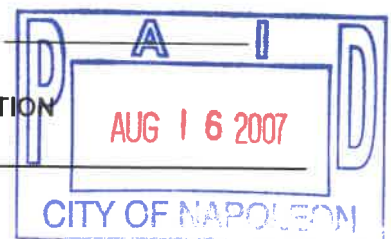

Zoning Permit Only!
other permits may be required

**THE CITY OF NAPOLEON
BUILDING & ZONING DEPARTMENT
255 W. RIVERVIEW
(419)592-4010**

Receipt Record

Page: 1

Receipt Number: RCPT2007-361

Date Printed: 8/16/2007

Received From: Risun Enterprises, LLC

Date: 8/16/2007

Reference #: SG2007-15

Received By: Angela

Amount: \$35.00

Comments: ck 3083

Fees:

FEE2007-449	Sign (Auto)	\$35.00
		<u>\$35.00</u>

Accounts:

100-3100-46610	Sign Permits	\$35.00
		<u>\$35.00</u>

THANK YOU FOR YOUR PAYMENT



CITY OF NAPOLEON
BUILDING & ZONING DEPARTMENT
255 W. Riverview Avenue, PO Box 151, Napoleon, OH 43545
Phone: 419-592-4010 - Fax: 419-599-8393

APPLICATION FOR SIGN PERMIT

LOCATION OF PROPERTY: 800 GLENWOOD

OWNER NAME: FIRST CHURCH OF CHRIST PHONE: 419-599-1156

OWNER ADDRESS: 800 GLENWOOD, NAPOLEON

CONTRACTOR NAME: RISUN ENTERPRISES LLC PHONE: 419-446-2972

IS CONTRACTOR REGISTERED WITH THE CITY OF NAPOLEON? YES NO

SIGN INFORMATION

TYPE: POST WALL GROUND AWNING

DIMENSIONS: 4' x 8' = TOTAL S.F. 32

** PLEASE INCLUDE ANY AND ALL SITE PLANS AND PLANS OF ABOVE SIGNS. ALREADY GIVEN TO TOM ZIMMERMAN

FEES:

\$35.00 BASE UP TO 50 S.F. OF SIGN, PLUS \$0.20 PER ADDITIONAL S.F., NOT TO EXCEED \$150.00

\$5.00 FLAT FEE FOR TEMPORARY SIGNS, TEMPORARY SPECIAL EVENT SIGNS, AND PORTABLE SIGNS OTHER THAN THOSE EXEMPT FROM FEE.(SEE BELOW)

NO FEE REQUIRED FOR TEMPORARY AND EASILY REMOVABLE 1ST AMENDMENT SIGNS, OR SIGNS RELATED TO RELIGIOUS OR CHARTIABLE CAUSES OR EVENTS.

[Signature]
APPLICANTS SIGNATURE

8-13-07
DATE

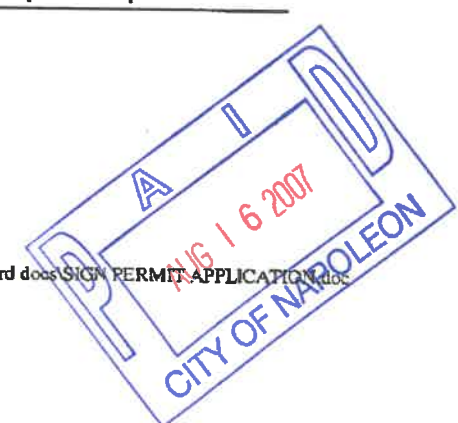

SERIES 100 4X8

572-0699

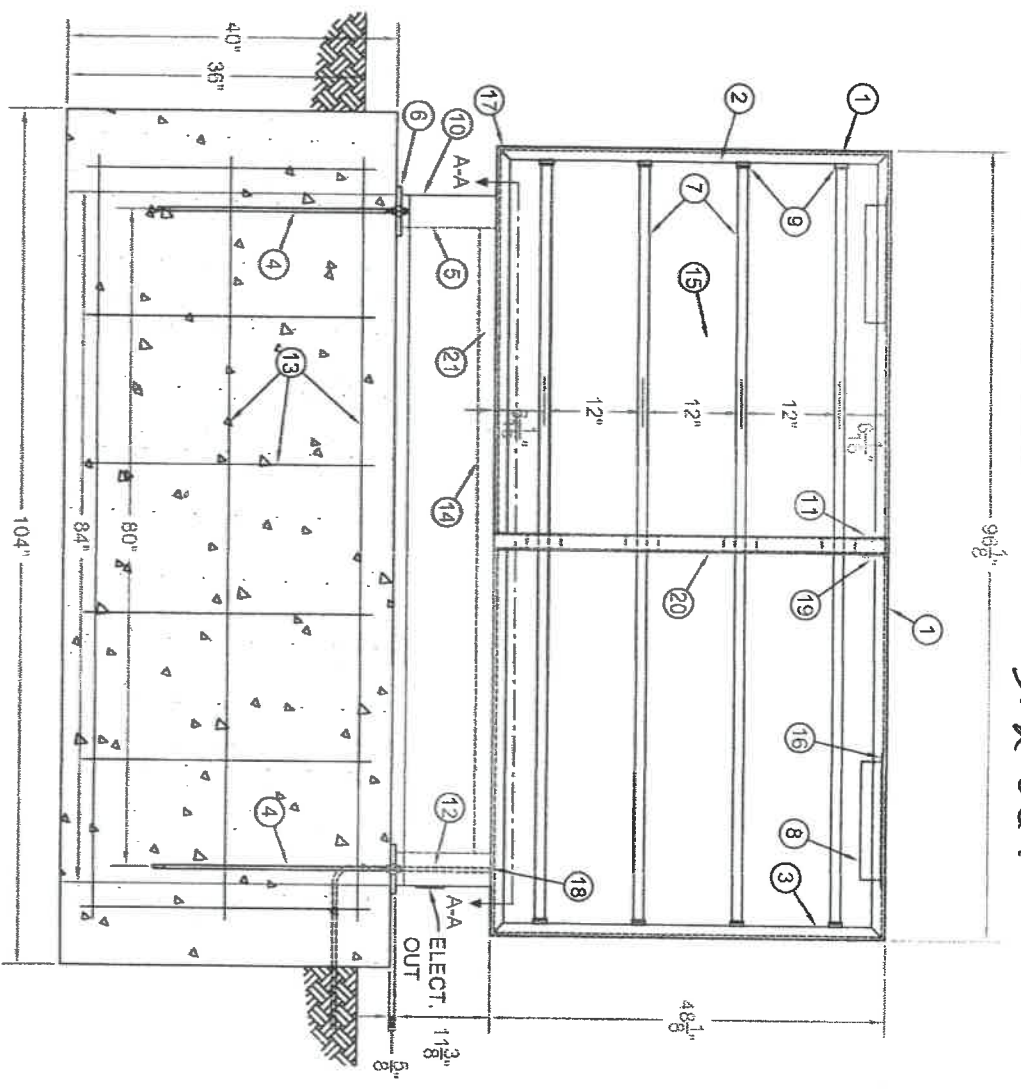
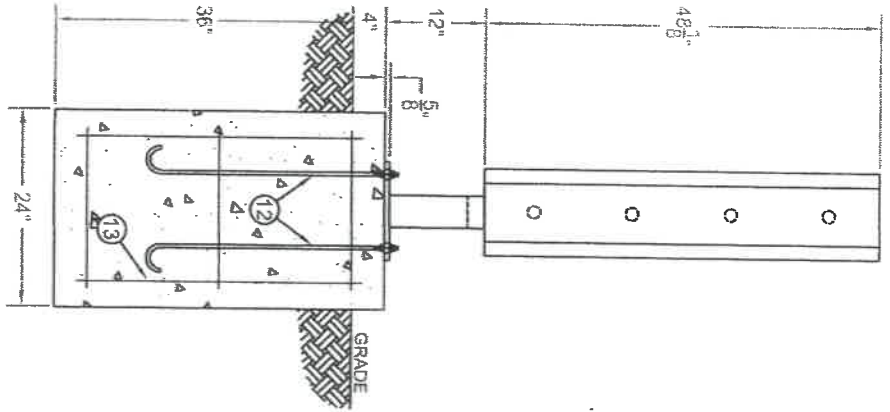

FOOTING SPECIFICATIONS

PROVIDE 1 HOLE - 3'-0" DEEP X 8'-8" LONG X 2'-0" WIDE
 . LESS THAN 2.5 CUBIC YARDS OF CONCRETE NECESSARY
 Foundation engineering should be reviewed by local authorities due to
 varying soil & wind load conditions. local frost line requirements may
 supercede depth dimension.

NOTICE: THIS IS FOR BID PURPOSES ONLY. DESIGN
 FACTORS MAY VARY WHEN ACTUAL ORDER IS PLACED.

- ① 10" EXTRUDED ALUMINUM FILLER
- ② 24 GAUGE GALVANIZED RACEWAY
- ③ 1 1/2" X 1 1/2" ALUMINUM RETAINER
- ④ 1 3/8" X 30" ANCHOR BOLTS - 4 REQUIRED
- ⑤ 4" X 4" X 3/8" STEEL SQUARE TUBE
- ⑥ 6" X 12" X 5/8" STEEL BASE PLATE
(WELDED TO LEGS AT FACTORY)
- ⑦ LAMPS - F96T12 CW/HO - 4 REQUIRED
- ⑧ E295 - 2 REQUIRED
- ⑨ SOCKETS - KULKA DOUBLE CONTACT
SNAP IN LAMP/holders 582GDF & 583GDF
- ⑩ 22 GAUGE GALVANIZED SHROUD
- ⑪ 2" X 3" X 1/4" ALUMINUM ANGLE
- ⑫ 1/2" FLEXIBLE CONDUIT (SUPPLIED BY INSTALLER)
- ⑬ #5 REBAR GRADE 60 OR BETTER TIE EACH
JOINT (SUPPLIED BY CUSTOMER)
- ⑭ 2" X 4" X 3/8" STEEL TUBE
- ⑮ H-BAR
- ⑯ 2" X 3/8" ALUMINUM FLATBAR - 2 REQUIRED
- ⑰ 1 1/2" X 1 1/2" X 3/8" ALUMINUM ANGLE
- ⑱ ELECTRIC OUT PROVISION
- ⑲ 5/8" - 12 CASE HARDENED SELF DRILLING
SCREWS - 4 REQUIRED
- ⑳ 2" X 4" X 3/8" STEEL TUBE
- ㉑ 3/8" X 1" BOLTS - 4 REQUIRED